

KATASTARSKO TOPOGRAFSKI PLAN
parcele top. br. 5709 i 5710 KO Pan~evo

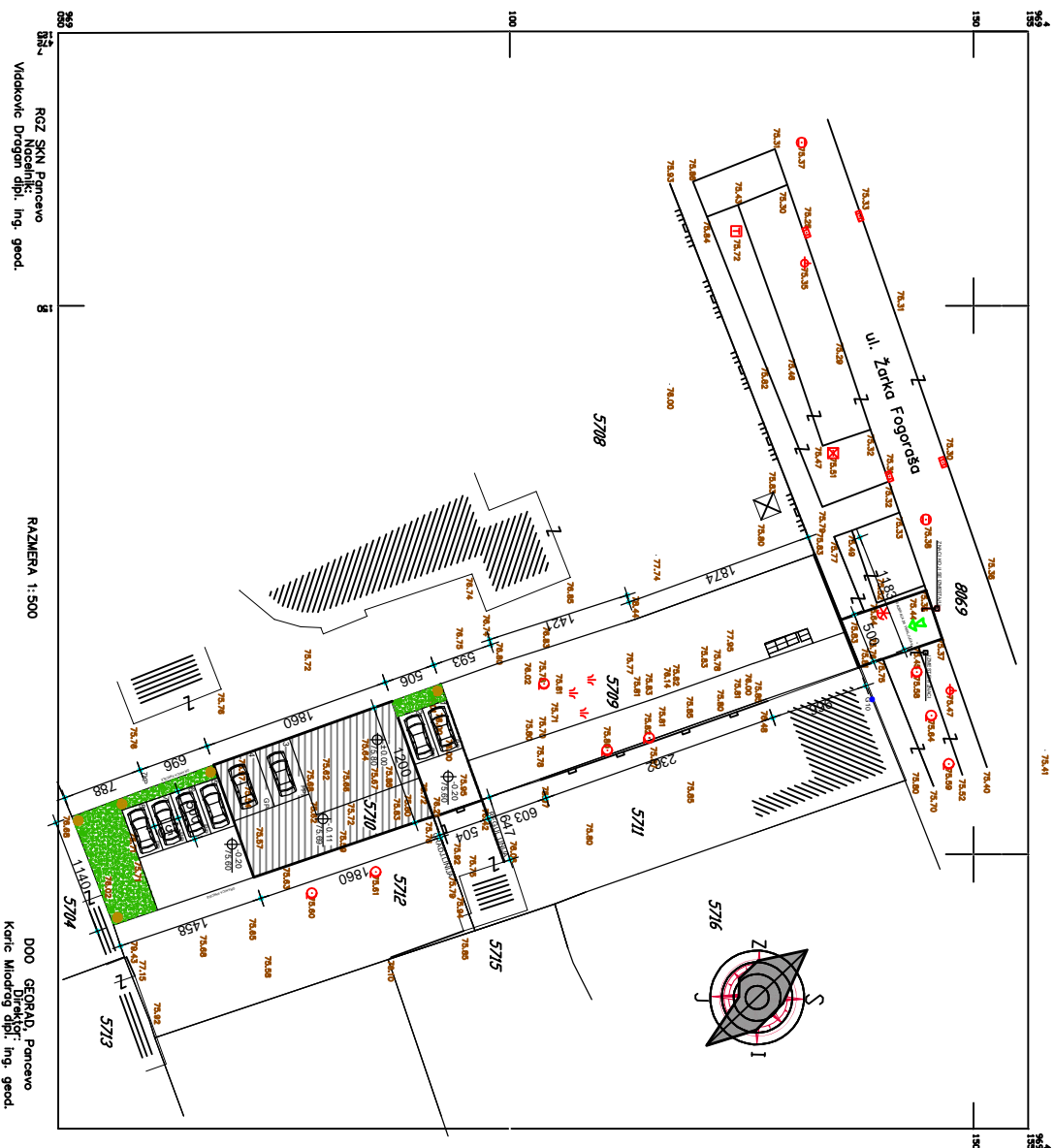

URBANISTIČKI PARAMETRI		
PARAMETRI DEFINIS. PLANOM	OSTVAR. PARAMETRI	
POVRŠINA PARCELE	260,00m ²	461,00m ²
SIRINA PARCELE	9,00m ²	11,70m ²
BR. G.P. STAMBENOG OBJEKTA (GRABNI OBJEKTA)		782,27m ²
BR. G.P. STAMBENOG OBJEKTA (GRABNI OBJEKTA)		217,68m ²
INDERS ZAUIZETOSTI	max80%	48%
INDERS IZGRADIVENOSTI	/	1,73
UKUPNO FORMIRANIH STAMBENIH JEDINICA		8
UKUPNA POVRSINA ZELENILA NA PARCELI	20% površine parcele (90,20 m ²)	44,78 m ² (bruto koške) 15,72 m ² (neto koške) 28,96m ² (ostvarenje)
PARKING PROSTOR	1Sj=1PM	8P-M
MAKSIMALNA SPRATNOST	P+1+Ps	P+1+Ps
VISINA SIEMENA	12,50	12,10m
VISINA VENCA	8,50	5,92m

P + 1 + Ps
Namena: Vseporodnični stambeni objekat Pan evo

NAPOMENA: SITUACIONO RESENJE NA PARCELI BROJ 5710 KO PANČEVO, URADJENO JE NA DIGITALNOJ PODLOZI KOJU JE IZGRADLO PREDUZEĆE ZA GEODETSKE POSLUGE GEORAD

	Oznaka	Broj projekta
	Urbanistički projekat	LP-1/2016
Klasifikacioni broj 112212 Kategorija B		Datum
Investitor Amber PRO - DOO		
V. Radonija Puhlika br.1 Pan evo		
Parcevo Zarko Fogođačka 20		
Lokacija k.p. 5710 KO Pančevo		
Ovi urbanista arh. Maja Begović Rade		
Br. licence 300 3536 03		
Projektant, sar. teh. Lilijana Matović		
Situacija	Razmera	Br. lista
	1:500	1

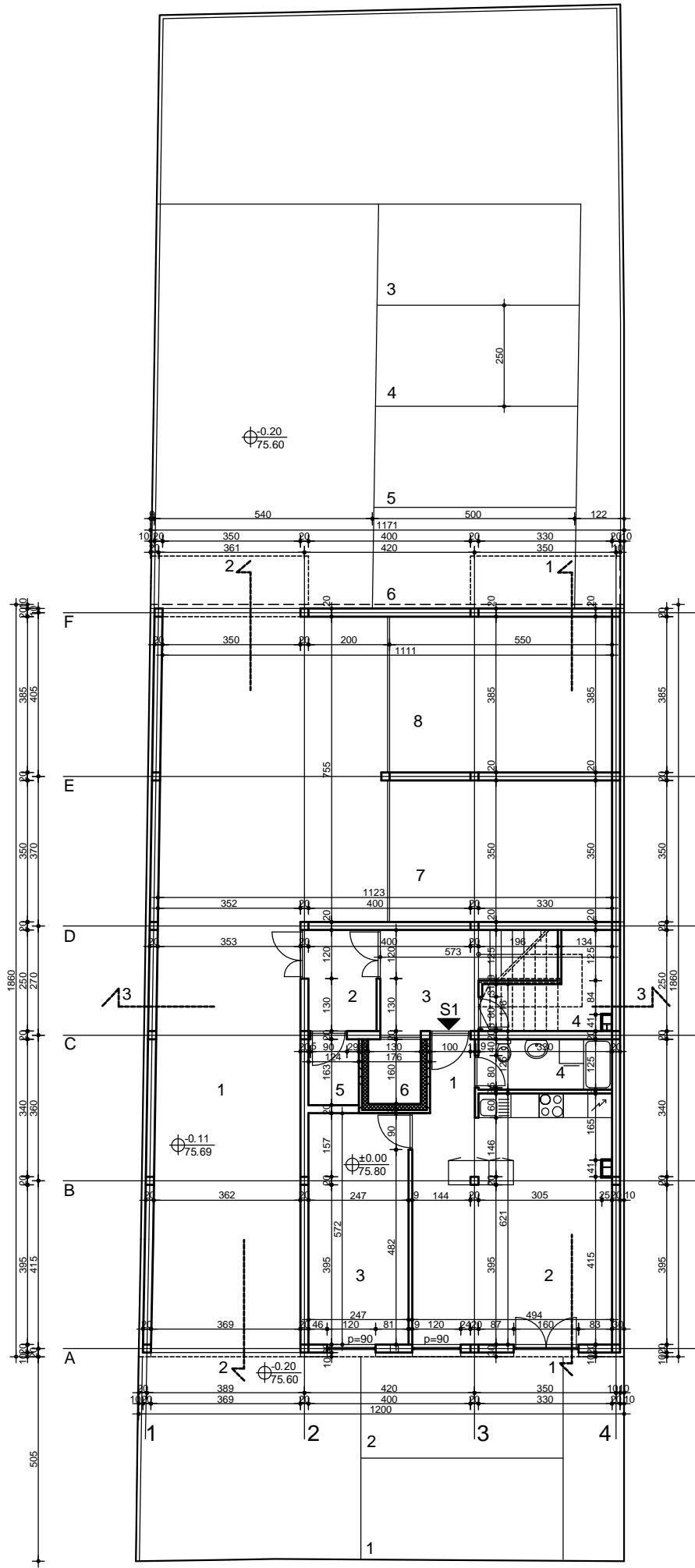

STAN 1 JEDNOSOBBAN

RB	NAZ.PROŠT.	P m2	Oml	POD
1	PREDSOBLJE	2.03	5.88	parket
2	D.S.TRP.KUH.	29.86	21.51	p.k.pl
3	SOBA	14.15	16.38	parket
4	KUPATILO	4.12	9.10	ker.pl.
UKUPNO		50.16m2		

ZAJEDNI KE PROSTORIJE

RB	NAZ.PROŠT.	P m2	Oml	POD
1	PROLAZ	82.94	48.66	beton
2	VETROBRAN	4.21	8.36	ker.pl.
3	STEP.PROŠT.	6.07	9.86	ker.pl.
4	PR.ZA HIGIJ.	5.40	11.42	ker.pl.
5	TEHN.PROŠT.	2.03	5.74	ker.pl.
6	LIFT	2.08		
7	GARAŽA za inv.	19.25	18.00	beton
8	GARAŽA	21.10	18.70	beton
UKUPNO		143.08m2		

NETO POVRŠINA PRIZEMLJA 193.24m2
 BRUTO POVRŠINA PRIZEMLJA 217.66m2
 NETO POVRŠINA OBJEKTA 669.48m2
 BRUTO POVRŠINA OBJEKTA 782.27m2

LEGENDA MATERIJALA

- ARMIRANI BETON
- GITER BLOK
- TERMO BLOK
- ŠUPLJA OPEKA
- TERMOIZOLACIJA

OSNOVA PRIZEMLJA

	Oznaka teh.dok.	Oznaka projekta	Broj projekta
	IDR	1	71
			Datum 11.2016
	Investitor	Investitor „Amber PRO“ DOO	
	Naziv objekta	V. Radomira Putnika br.1 Pan evo	
	Ovl.projektant	objekat Pan evo	
	Br.licence	arh.Maja Begović Rade	
Projektant, sar.	teh.Ljiljana Matovi		
Crtez (naziv)	Faza	Razmera	Br.lista
Osnova prizemlja	A	1:100	2

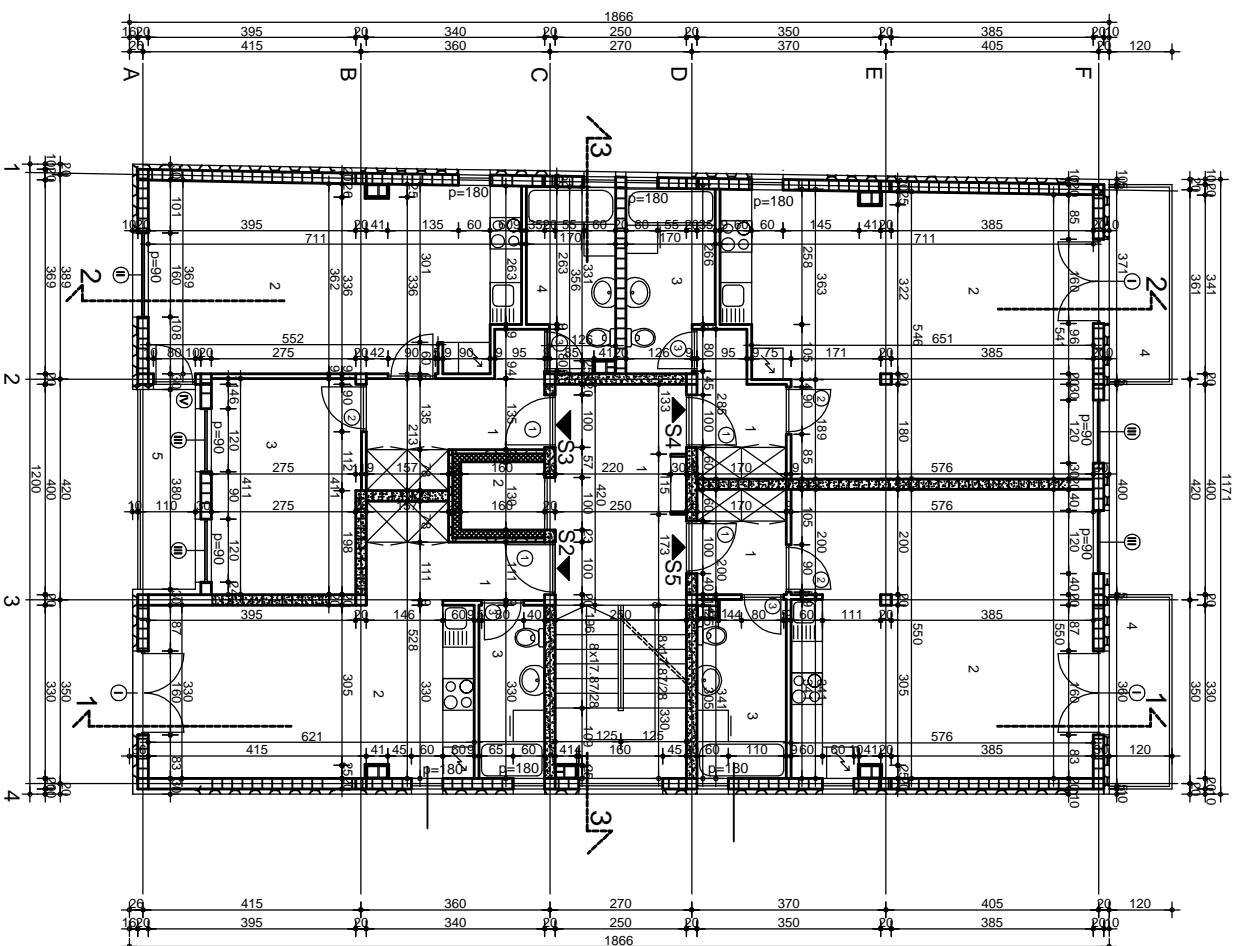

STAN 2 GARSONIJERA

REI NAZ. PROST.	P m ²	Omi	POD
1. PREDSOBLJE	2.03	5.88	paket
2. D.S.TRP. KUHI.	23.60	23.20	D.K.pli
3. KUPATILO	4.12	9.10	ker.pli
UKUPNO	29.75m²		

STAN 3 DVOSOBAN

REI NAZ. PROST.	P m ²	Omi	POD
1. PREDSOBLJE	6.72	12.94	paket
2. D.S.TRP. KUHI.	25.72	22.83	D.K.pli
3. SOBNA	11.31	13.72	paket
4. KUPATILO	5.78	10.69	ker.pli
5. TERASA	4.18		
UKUPNO	53.71m²		

STAN 4 JEDNOSOBAN

REI NAZ. PROST.	P m ²	Omi	POD
1. PREDSOBLJE	4.06	9.10	paket
2. D.S.TRP. KUHI.	36.21	25.30	D.K.pli
3. KUPATILO	5.73	10.63	ker.pli
4. TERASA	4.66		
UKUPNO	50.66m²		

STAN 5 JEDNOSOBAN

REI NAZ. PROST.	P m ²	Omi	POD
1. PREDSOBLJE	3.40	7.40	paket
2. D.S.TRP. KUHI.	31.64	23.72	D.K.pli
4. KUPATILO	5.79	10.22	ker.pli
5. TERASA	4.44		
UKUPNO	45.27m²		

ZAJEDNI KE PROSTORJE

REI NAZ. PROST.	P m ²	Omi	POD
1. STEP. PROST.	18.76	20.00	ker.pli
2. LIFT	2.07		
UKUPNO	20.83m²		

NETO POUVRŠINA I SPRATA 200.22m²
BRUTO POUVRŠINA I SPRATA 231.54m²

LEGENDA MATERIJALA

- ARMIRANI BETON
- GITER BLOK
- TERMO BLOK
- ŠUPLJA OPEKA
- TERMOIZOLACIJA

OSNOVA I SPRATA

	Investitor	V. Radomirna Parutka br.1 Pan. evo	Oznaka projekta	71	Broj projekta	
	Investitor	"Amber PRO DOO"	Datum	11.2016		
	Naziv objekta	Visproizvodni stanovi	Oznaka	IDR	1	
	Projektori	objekat Pan. evo	Faza	A	Razmera	1:100
	Projektori	arh. Maja Begović, Rade Brlice	Osnova i sprata			3
	Projektori, sar.	teh. Lilijana Matović				

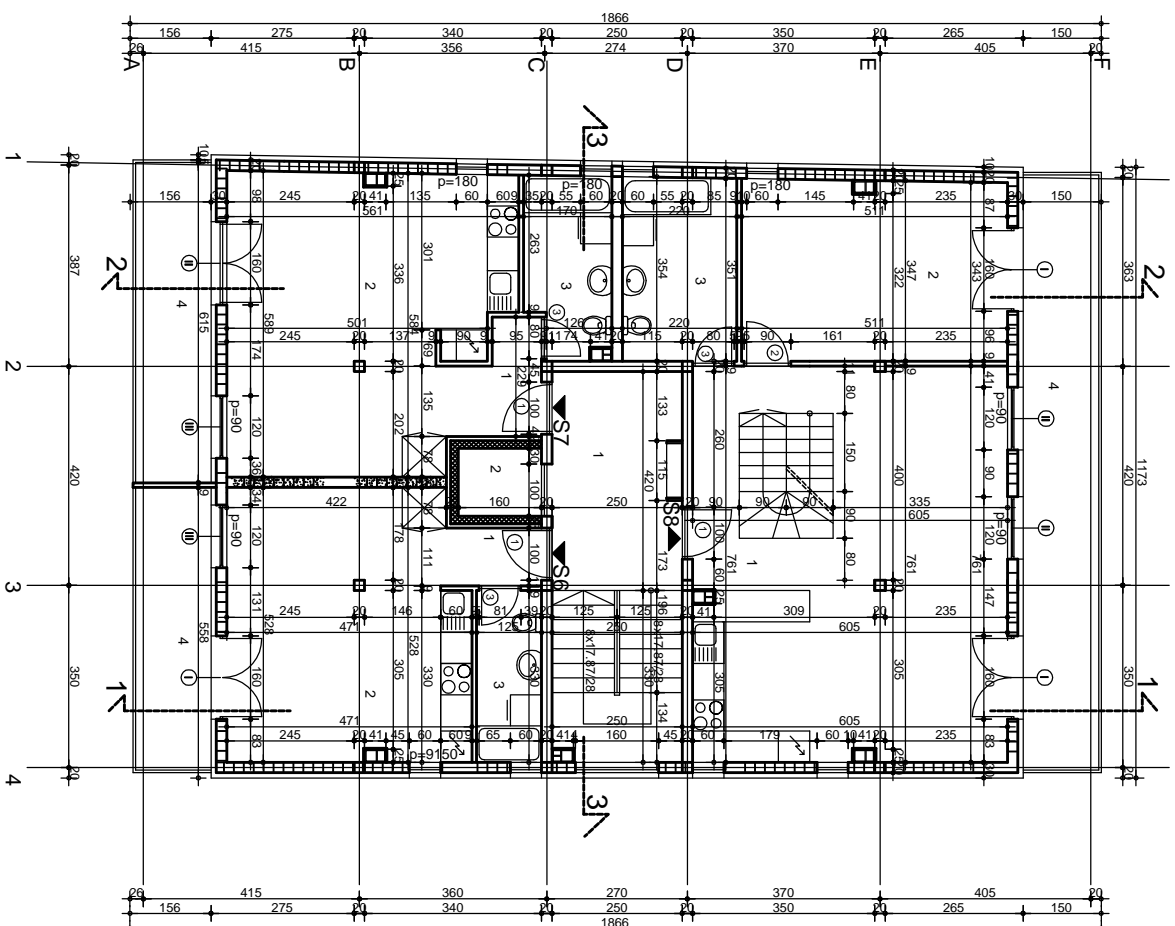

STAN 6 JEDNOSOBAN

RBI	NAZ. PROST.	P m ²	Omi	POD
1	PREDSOBLJE	2.03	5.88	parket
2	D.S. TRP. KUH.	23.88	20.20	pl.kp
3	KUPATILO	4.12	9.10	ker.pl.
4	TERASA	8.22		ker.pl.
UKUPNO		38.25m ²		

STAN 7 JEDNOSOBAN

RBI	NAZ. PROST.	P m ²	Omi	POD
1	PREDSOBLJE	2.18	6.48	parket
2	D.S. TRP. KUH.	30.68	26.42	p.k.pl.
3	KUPATILO	5.77	10.67	ker.pl.
4	TERASA	9.42		ker.pl.
UKUPNO		48.05m ²		

STAN 8

RBI	NAZ. PROST.	P m ²	Omi	POD
1	D.S. TRP. KUH.	46.06	27.32	p.k.pl.
2	SOBA	18.14	17.32	parket
3	KUPATILO	7.94	11.62	ker.pl.
4	TERASA	17.41		ker.pl.
UKUPNO		89.55m ²		

ZAJEDNI KE PROSTORJE

RBI	NAZ. PROST.	P m ²	Omi	POD
1	STEP. PROST.	18.76	20.00	ker.pl.
2	LIFT	2.07	5.50	
UKUPNO		20.83m ²		

NETO POUŠIŠNA POV. SPRATA 196.68m²
BRUTO POUŠIŠNA POV. SPRATA 222.21m²

LEGENDA MATERIJALA

- ARMIRANI BETON
- GITER BLOK
- TERMO BLOK
- ŠUPLJA OPEKA
- TERMOZOLACIJA

OSNOVA POV. SPRATA I NIVO

	Oznaka	Oznaka	Broj projekta
	teh.dok	projekta	71
	IDR	1	Datum
			11.2016
Investitor	Investitor	„Amber PRO“ DOO	
Naziv objekta	V. Radomir Pauićka br.1 Pan. ovo	Visporodni stambeni objekat Pan. ovo	
Ovi. projektant	arh. Maja Begović Rade		
Br. licence	300.3536.03		
Projektant, sar.	teh. Ljiljana Matović		
Crtez (naziv)	Osnovna pov. sprata I nivo	Faza	Razmera
		A	1:100
			Br. lista
			4

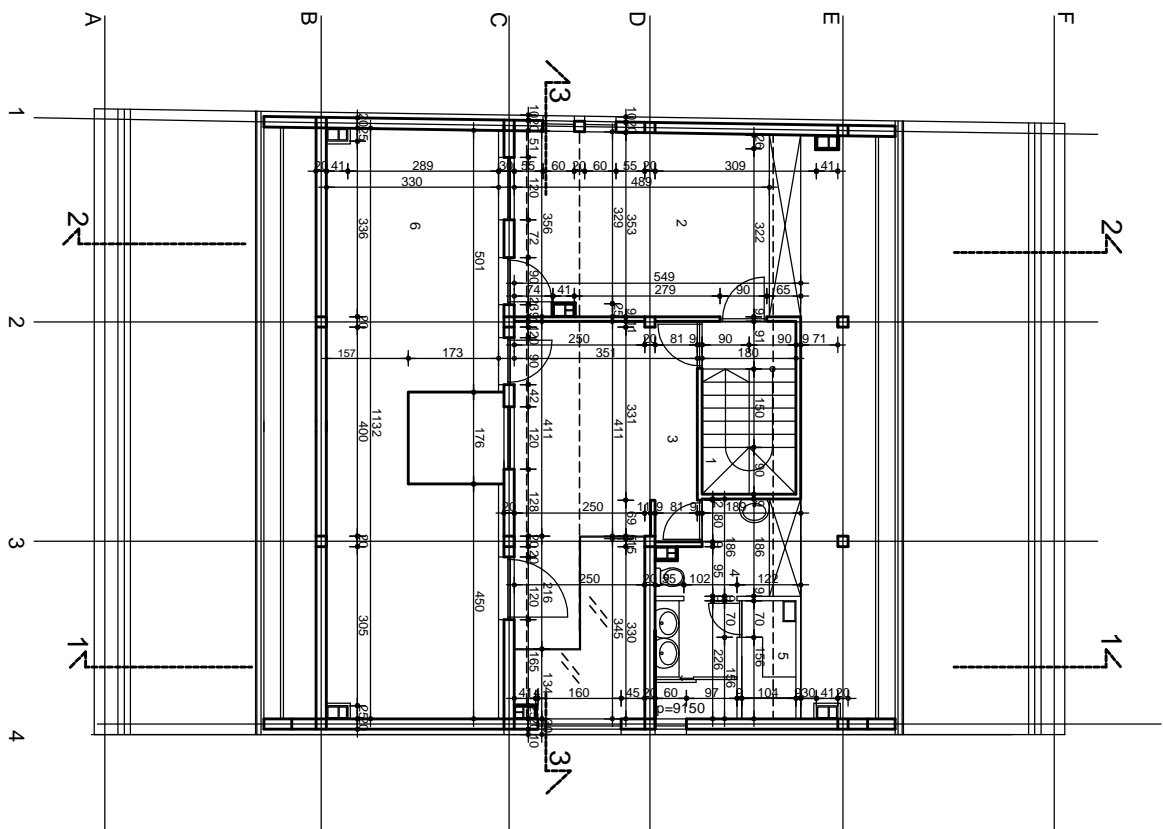

STAN 8 llinivo

RIBI NAZ. PROST.	P m ²	Oml.	POOD
1 ST. PROSTOR	5,36	10,22	parket
2 SOBA	17,00	16,64	parket
3 SOBA	13,45	16,58	parket
4 KUPATILO	7,07	12,94	kerpl.
5 SAJUNA	1,35	5,72	dr.pod
6 TERASA	34,51		kerpl.
UKUPNO	79,34		

NETO POKRŠINA POV. SPRATA llinivo 79,34m²
BRUTO POKRŠINA POV. SPRATA llinivo 110,86m²

LEGENDA MATERIJALA

	ARMIRANI BETON
	GITER BLOK
	TERMO BLOK
	ŠUPLJA OPERKA
	TERMOZOLUCIJA

OSNOVA POV SPRATA II nivo

	Oznaka	Oznaka	Broj projekta
	teh.dok.	projekta	71
	IDR	1	Datum
			11.2016
Investitor	Investitor - Amber PRO DOO		
Naziv objekta	V. Radomirja, Puntika br. 1 Pan. ovo.		
Objekt	Visporednici stambeni objekat Pan. ovo.		
Diz.projektant	arh.Maja Begović Rađe		
Br.licence	300/3536/03		
Projektant, sar.	teh.Lilijana Matović		
Čitez (naziv)	Faza	Razmera	Br.lista
Osnova pov.sprata II nivo	A	1:100	5

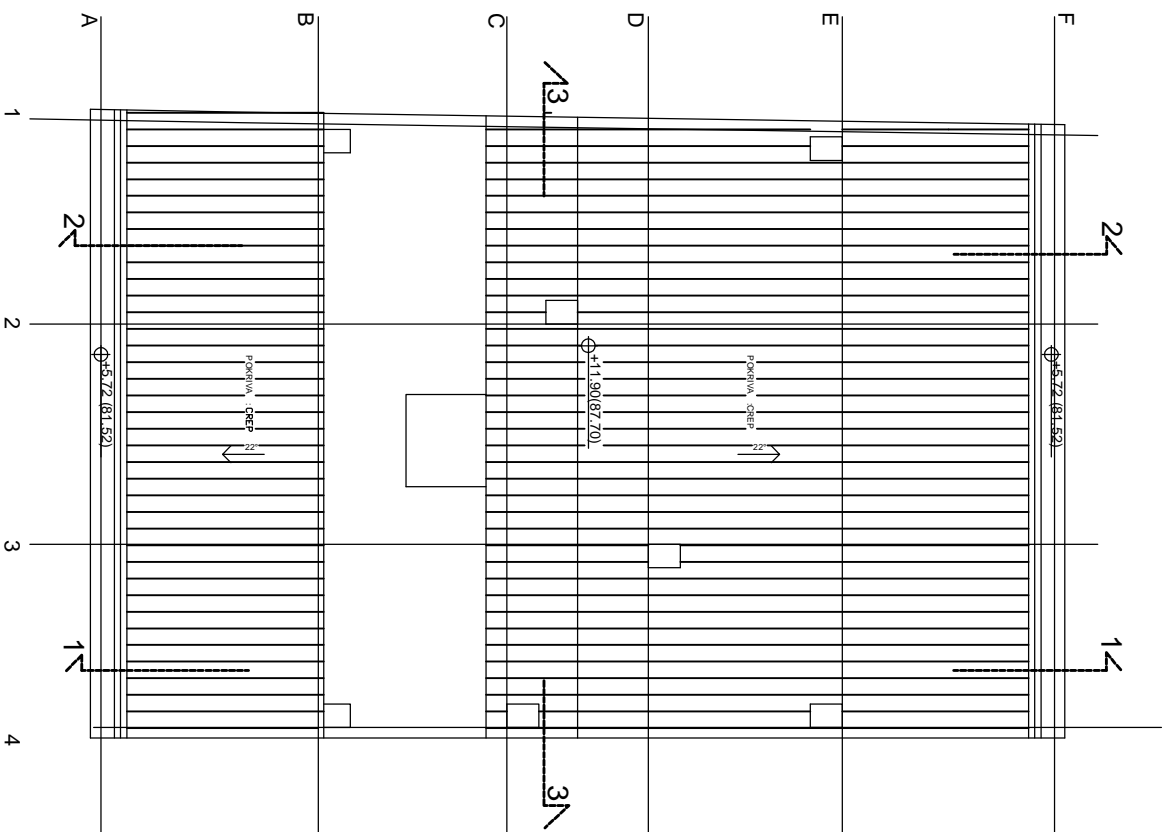

OSNOVA KROVNIH RAVNI

	Oznaka	Oznaka projekta	Broj projekta
	teh dok	71	Datum
IDR	1	11.2016	
Investitor	Investitor: "Amber PRO" DOO		
Naziv objekta	V. Bedonjski stanovi		
	objekat: Pan evo		
Ovi: projektant	arh. Maja Begović Radde		
Bil: licence	300.3536.03		
Projektant, sar.	teh. Lilijana Matovi		
Crtaz (naziv)	Faza	Razmera	Br: lista
Osnova krovnih ravni	A	1:100	6

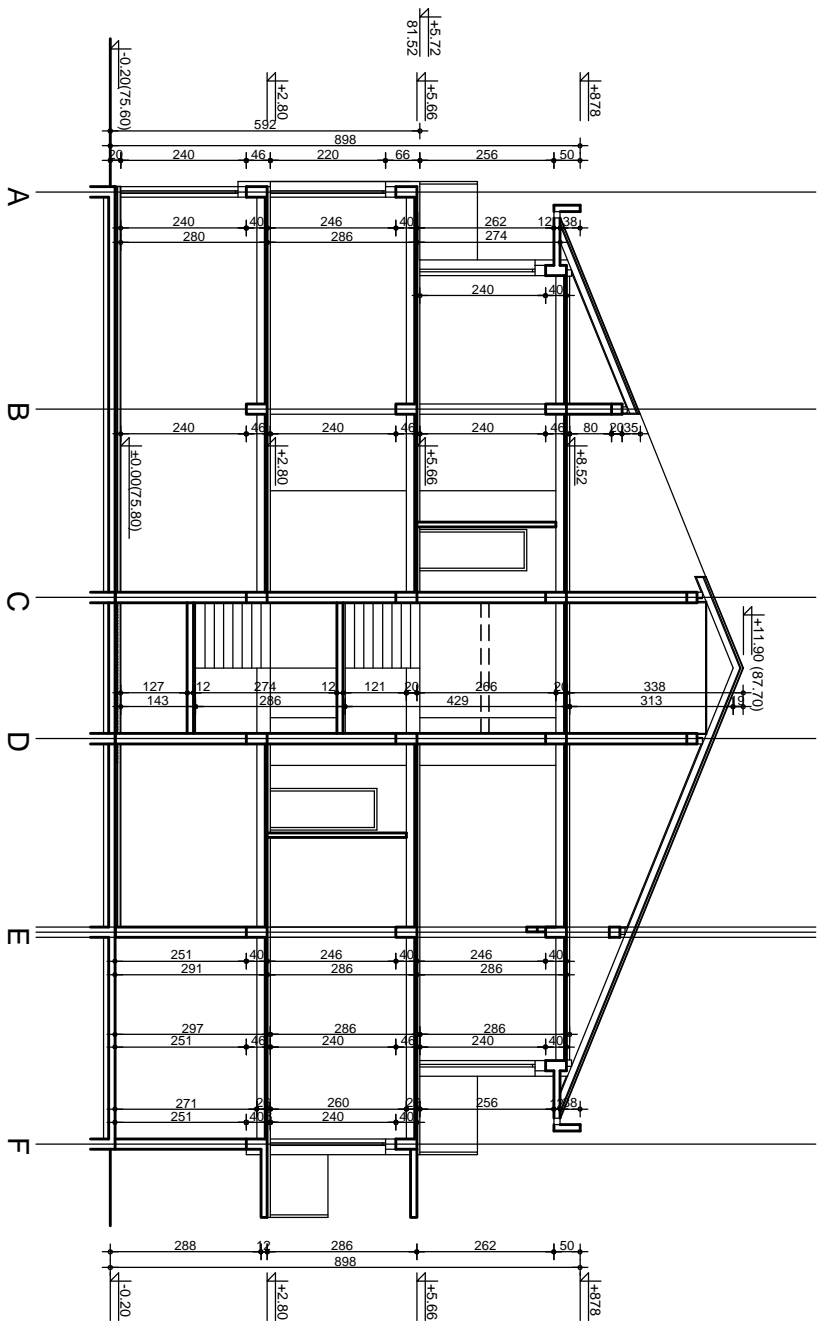

- LEGENDA MATERIJALA**
- ARMIRANI BETON
 - GITER BLOK
 - TERMO BLOK
 - ŠUPLJA OPEKA
 - TERMOZOLACIJA

PRESEK 1-1

	Oznaka teh. dok.	Oznaka projekta	Broj projekta
	IDR	1	71
Investitor	Investitor	Amber PRO DOO	Datum
Naziv objekta	V. Radomir Puškica br. 1 Pan. ovo	Visporednici stambeni objekat, Pan. ovo	11.2016
Ovi projektant	am. Maja Begović, Rade		
Br. licence	300 3536 03		
Projektant, sar.	teh. Ljiljana Marović		
Crtež (naziv)	Faza	Razmera	Br. lista
Presek 1-1	A	1:100	7

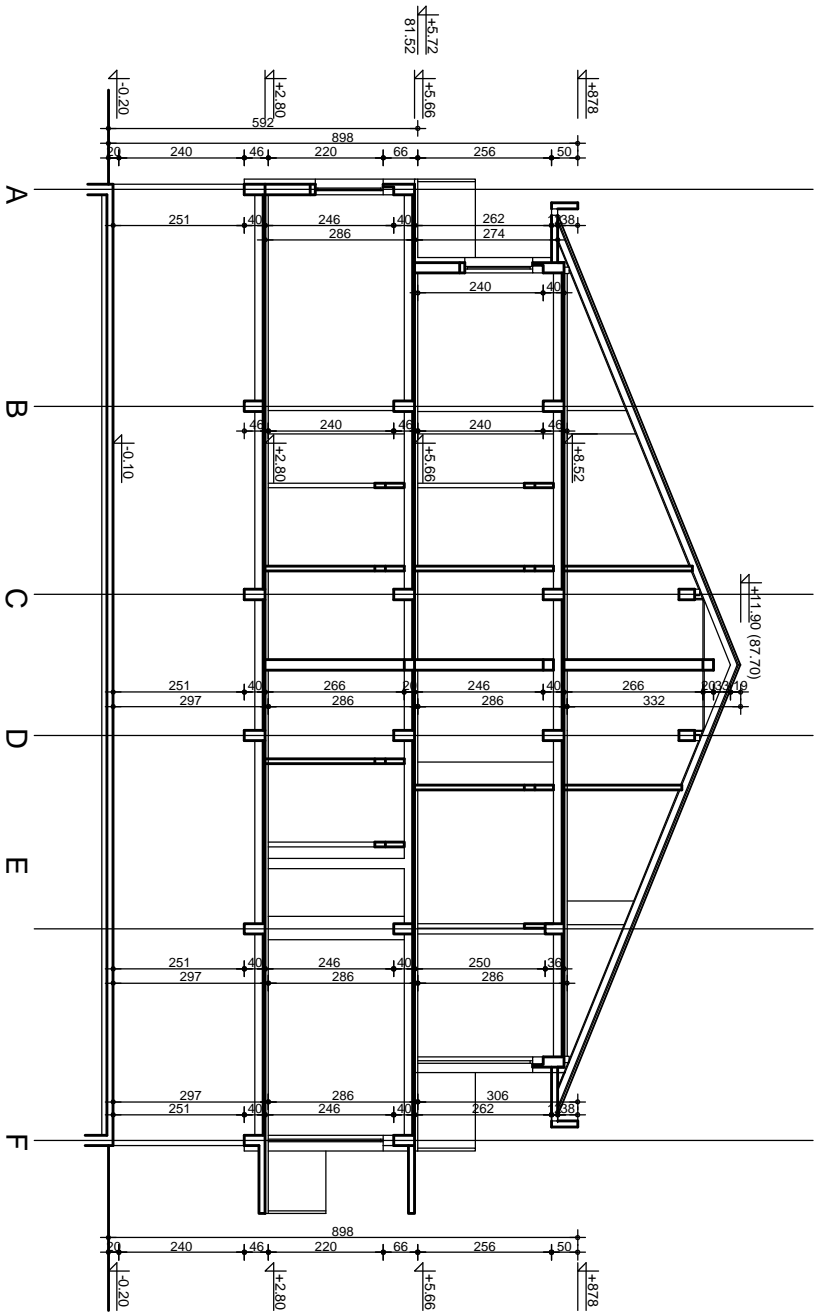

- LEGENDA MATERIJALA**
- ARMIRANI BETON
 - GITER BLOK
 - TERMO BLOK
 - ŠUPLJA OPEKA
 - TERMOZOLACIJA

PRESEK 2-2

		Oznaka teh.dok.	Oznaka projekta	Broj projekta
Investitor Naziv objekta Ovi projektanti Briljance Projektanti, sar.		IDR 1	"Amber PRO" DOO V. Radomira Puntika br. 1 Pan. ovo objekta Pan. ovo	71 11.2016
Teh. Ljiljana Matovi 300 3536 03		Investitor arh. Maja Begović, Rade		
Crtaz (naziv) Presjek 2-2		Faza A	Razmera 1:100	Br. lista 8

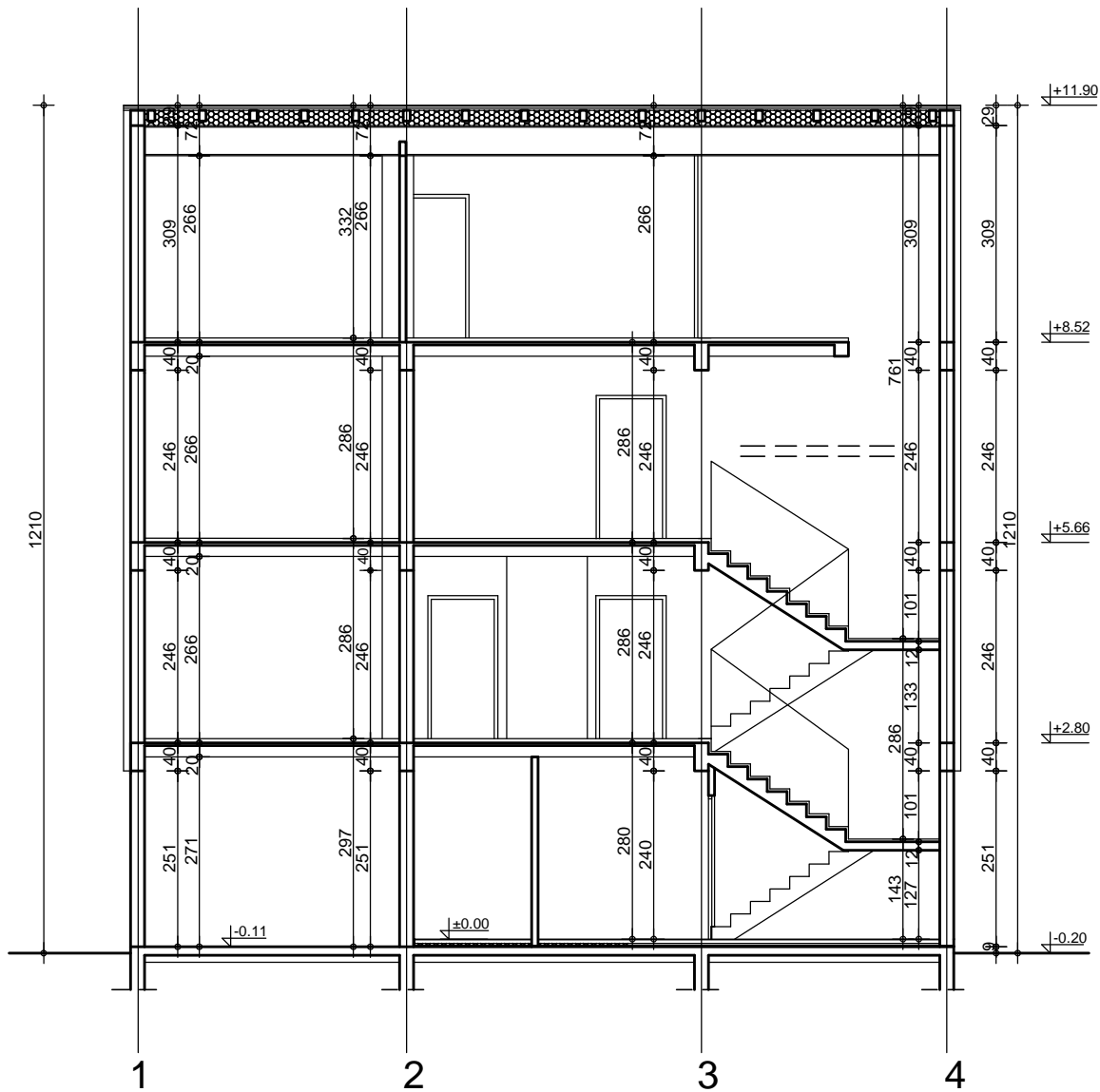

LEGENDA MATERIJALA

-  ARMIRANI BETON
-  GITER BLOK
-  TERMO BLOK
-  ŠUPLJA OPEKA
-  TERMOIZOLACIJA

PRESEK 3-3

	Oznaka teh.dok.	Oznaka projekta	Broj projekta
	IDR	1	71
	Investitor	Investitor „Amber PRO“ DOO	
	Naziv objekta	V. Radomira Putnika br.1 Pan evo	
	Ovl.projektant	arh.Maja Begović Rade	
	Br.licence	300 3536 03	
Projektant, sar.		teh.Ljiljana Matovi	
Crtez (naziv)		Faza	Razmera
Presek 3-3		A	1:100
			Br.lista
			9

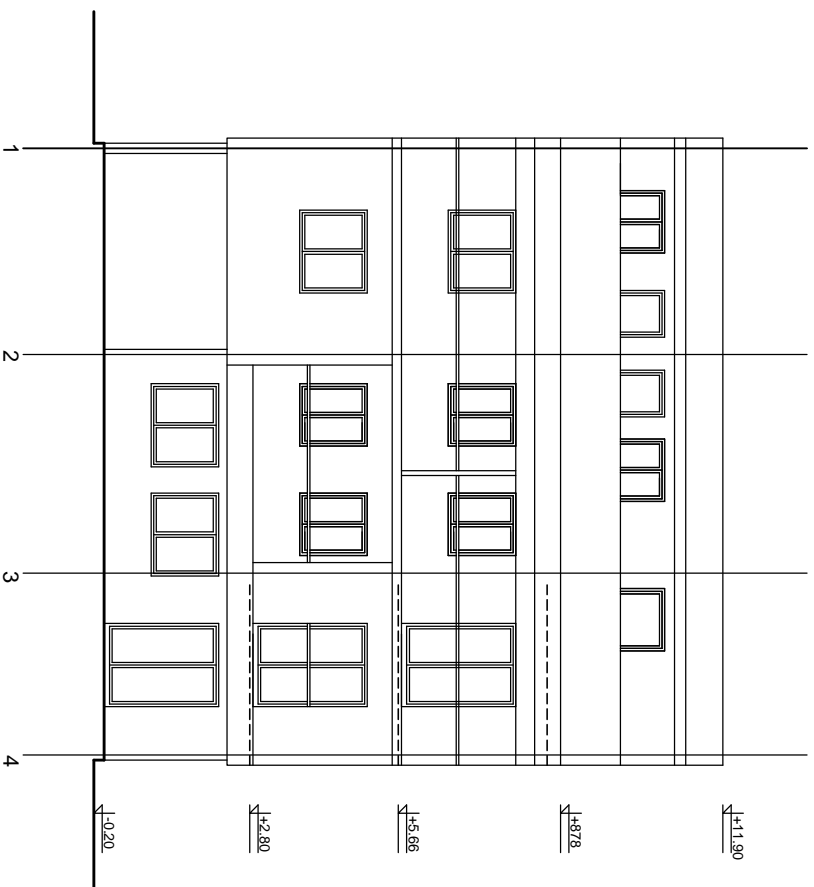

Severozapadna fasada

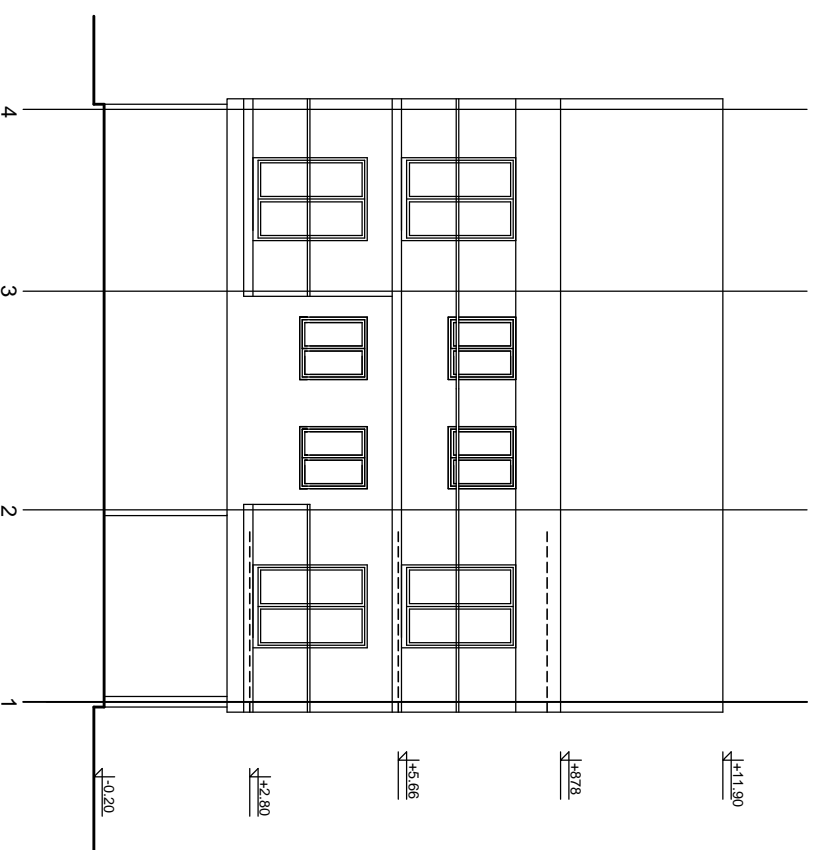

Jugoistocna fasada

SZ i JI fasada

	Oznaka teh. dok.	Oznaka projekta	Broj projekta 71
	IDR 1	1	Datum 11.2016
Investitor V. KADOMIĆA PUNJKIĆ BR.1 Pan. evo	Naziv objekta Vseporodni stanbeni objekat Pan. evo	Ovi projektant arh. Maja Begović Rade	Br. licence 300 3536 03
Projektant, sar.	Teh. Lilijana Marović	Faza A	Razmera 1 : 100
Crez (naziv) JI i SZ fasada	Br. lista 10		

Jugozapadna fasada

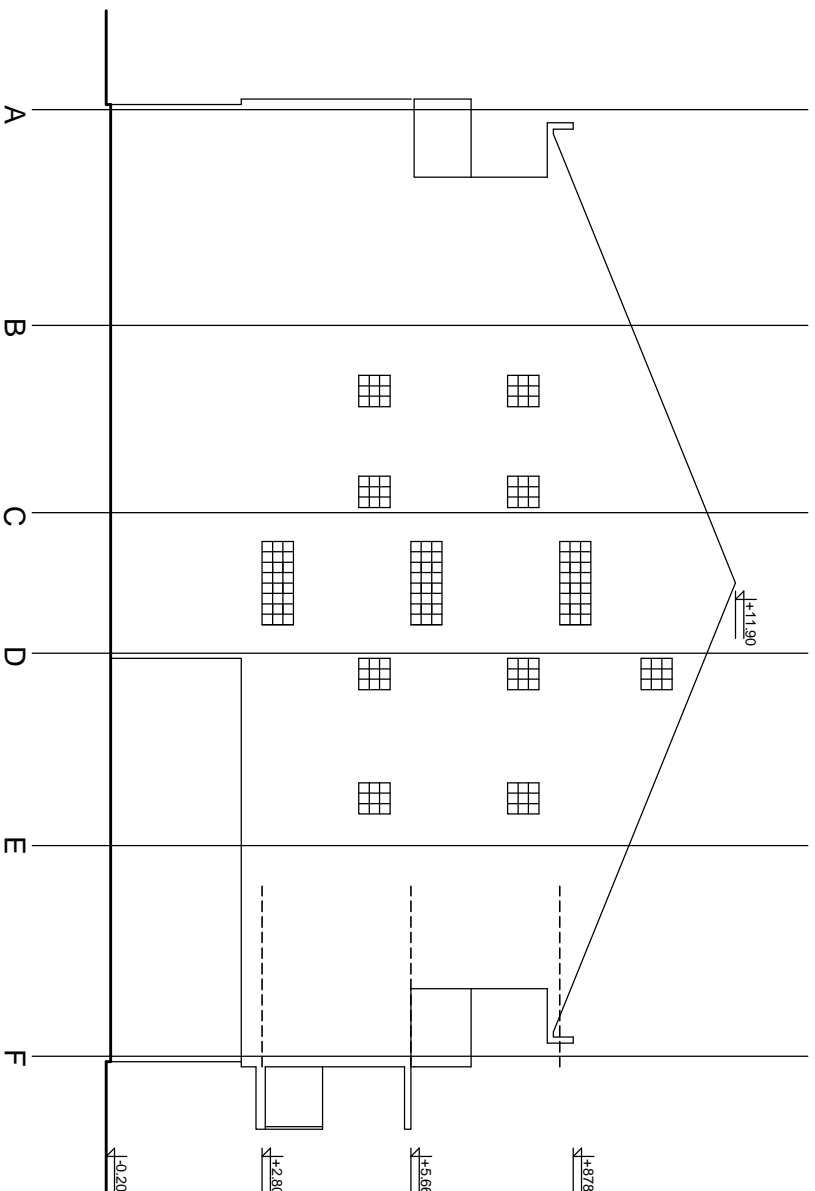

JUGOZAPADNA FASADA

	Oznaka	Oznaka 1	Broj projekta
	teh.dok.	projekta	71
	IDR	1	Datum
			11.2016
Investitor	Investitor "Amber PRO" DOO		
Mašiny objekta	V. Radomirna Putnik a br.1 Pan. evo		
Ovi projektant	Višepородični stambeni objekat Pan. evo		
Idilicence	arh. Majia Begović Rade		
Projektant: sar.	300 3536 03		
	teh. Ljiljana Matović		
Crtez (naziv)	Faza	Razmera	Br. lista
Jugozapadna fasada	A	1:100	11

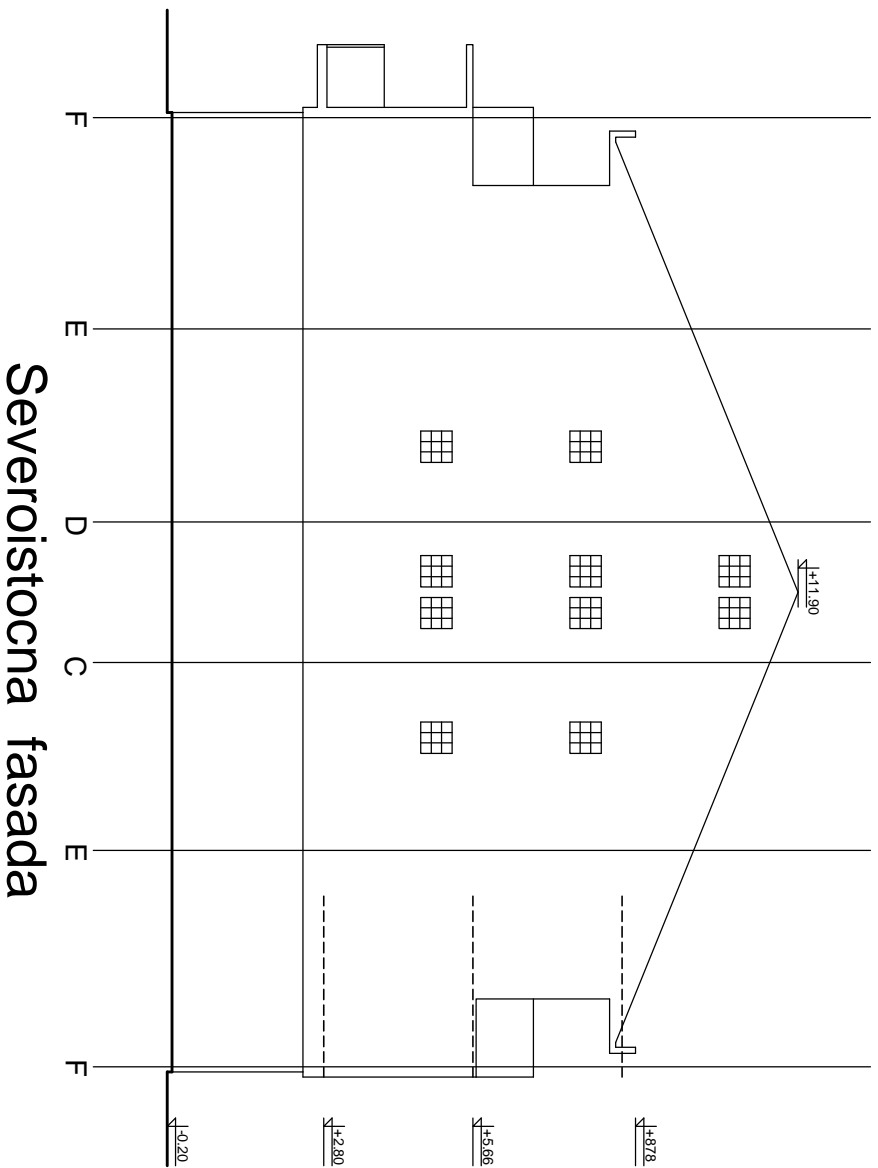

Severoistočna fasada

SEVEROISTOČNA FASADA

	Oznaka projekta	Oznaka projekta	Broj projekta
	teh. dok.	71	
IDR	1	Datum	11.2016
Investitor	Investitor „Amber PRO“ DOO		
Naziv objekta	V. Radomirna Puntika br. 1 Pan. evo.		
	Višepodrični stambeni objekat. Pan. evo.		
Ovl. projektant	arch. Maja Begović. Rade.		
Bri.license	300 3536 03		
Projektant, sar.	teh. Ljiljana Matović		
Crtez (naziv)	Faza	Razmera	Br. lista
Jugozapadna fasada	A	1:100	12